

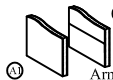

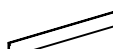

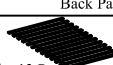



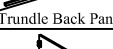
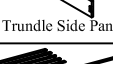

ASSEMBLY INSTRUCTION

A	 Arm	2 pcs
B	 Back Panel	1 pc
C	 Slat 13 Pcs	1 pc
D	 Front Side Rail (PU)	1 pc
E	 Back Side Rail	1 pc
F	 Trundle Front Panel (PU)	1 pc
G	 Trundle Back Panel	1 pc
H	 Trundle Side Panel	2 pcs
I	 Slat 13 Pcs	1 pc
J	 Wooden Block	4 pcs
K	 Middle Panel	1 pc

Packing Hardware		
1	 M5 x 70 mm	1 pc
2	 M5 x 65 mm	1 pc
3	 CSK M4 x 32mm	64 pcs
4	 JCBC M6 X 50	4 pcs
5	 SPRING WASHER	4 pcs
6	 FLAT WASHER	4 pcs
7	 Roller	6 pcs
8	 CSK M4 x 16 mm	24 pcs
9	 JCBB M8 X 20	8 pcs

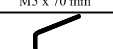
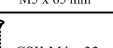
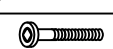

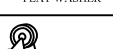
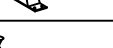
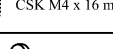
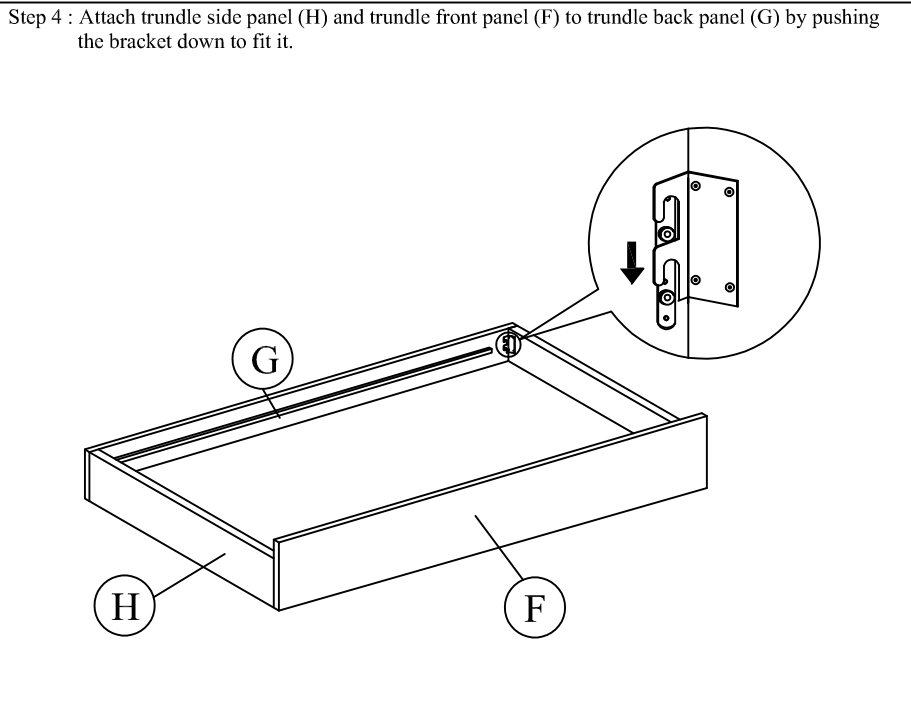
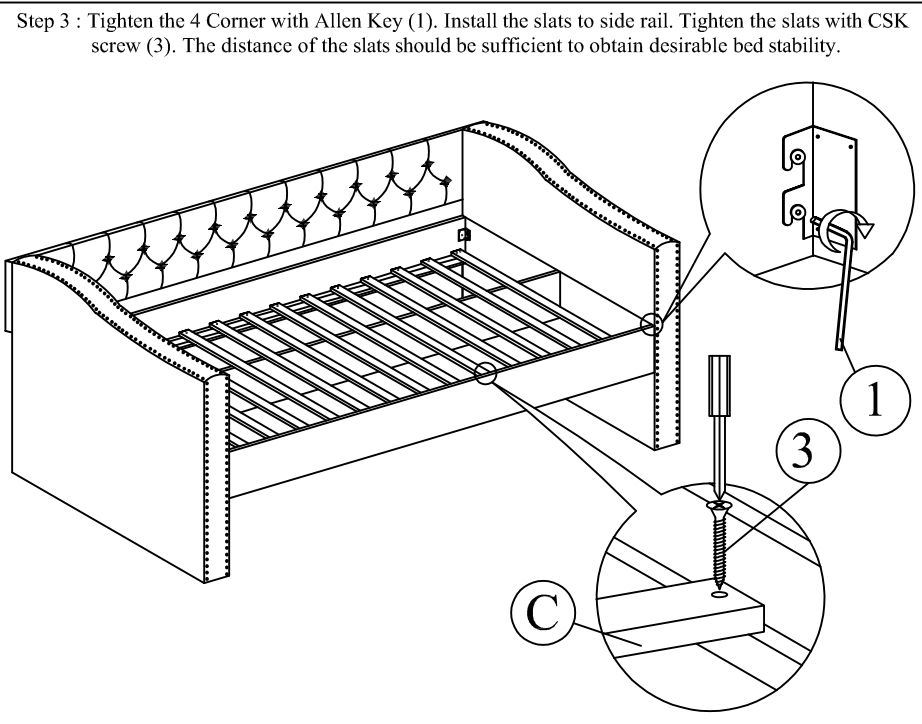
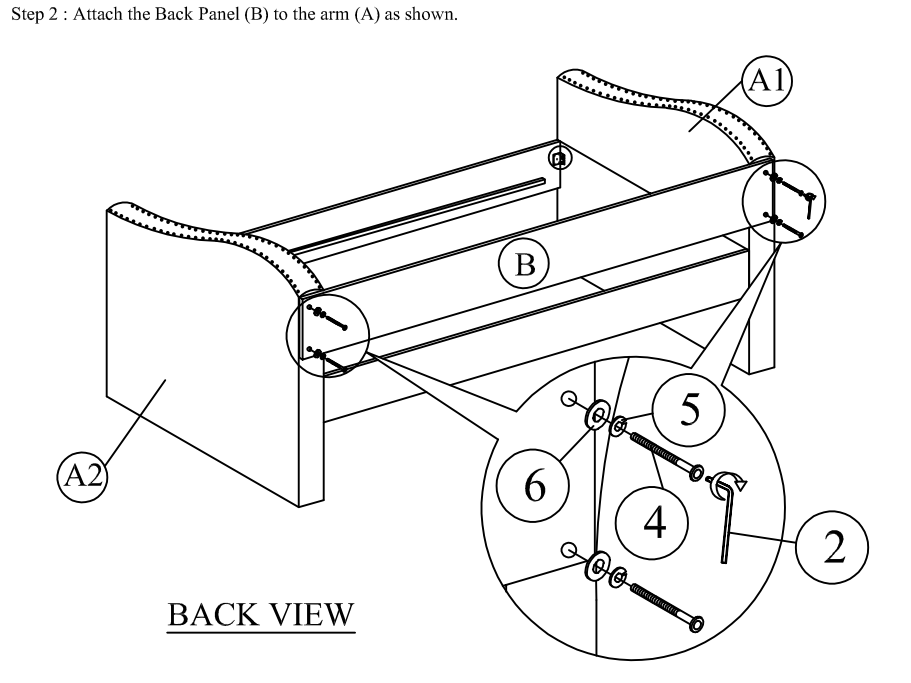
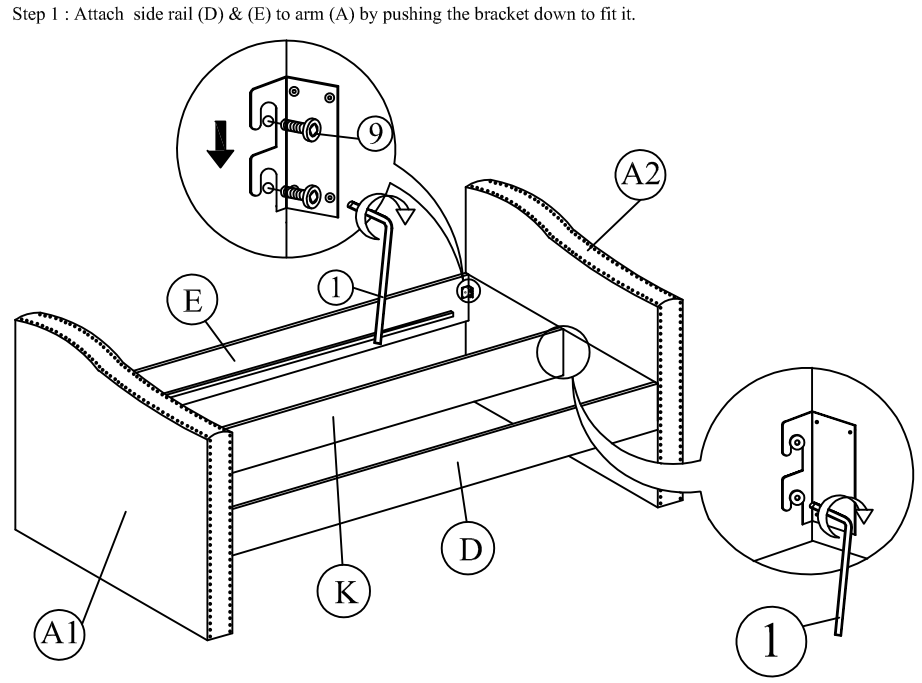
Step 5 : Affix the roller (7) to the slat (I) follow the marking on the slat (I).

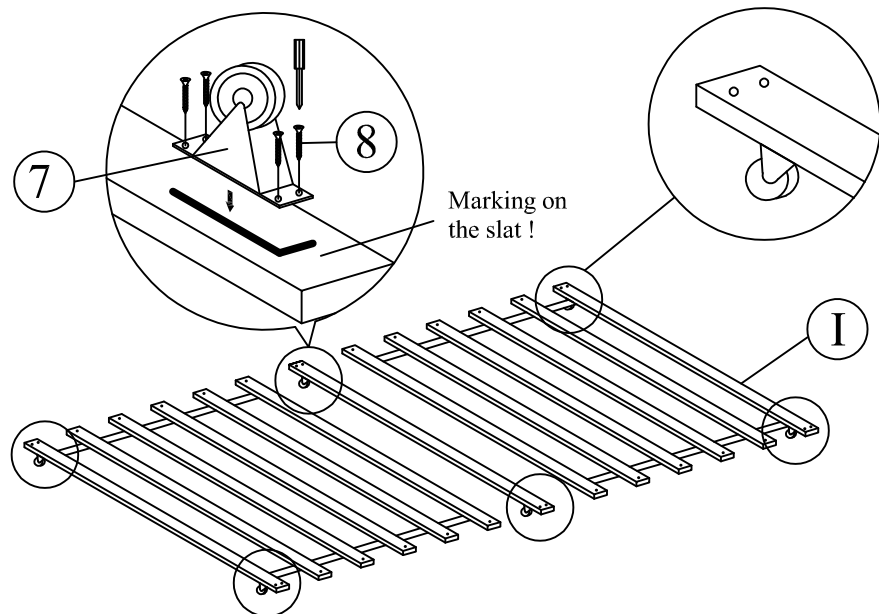

Step 6 : Place the wooden blocks (J) at the corner of the trundle and fix the slat (I) to the side rail at (E) & (F) .

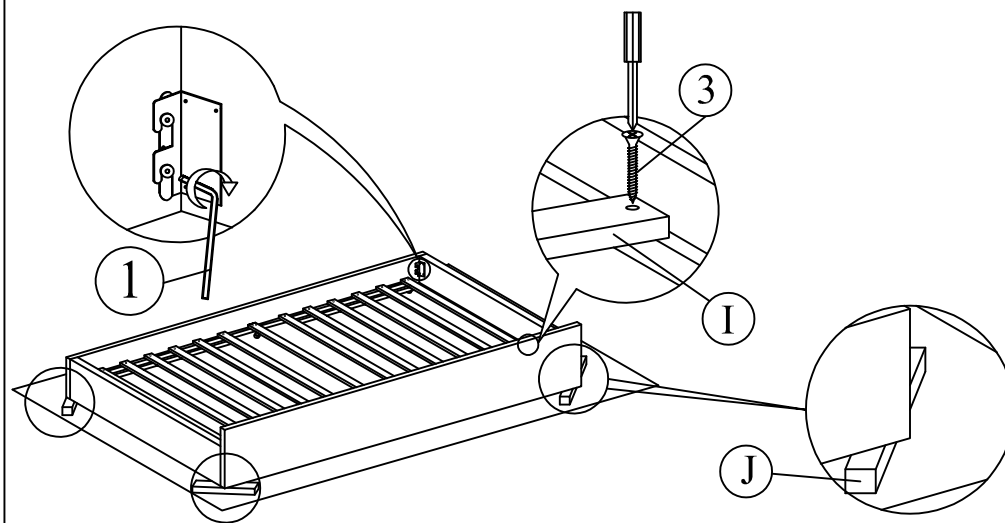

Step 7 : Assembly is complete.

